

Section 5

Accessories

TAIPAN

acting on impulse...

Can't find what your looking for? Contact us -



1300 654 782



07 5428 1311

All part numbers displayed in **BOLD ITALICS** are new items that may not be in stock as yet, please contact us for further details.

Clamps -Single-



Part Number	Description
8mm Single	
9.5mm Single	
12.7mm Single	Suits 1/4" 1 Wire
14mm Single	Suits 1/4" 2 Wire
15mm Single	
16mm Single	
18mm Single	Suits 3/8" 1 Wire
19mm Single	Suits 3/8" 2 Wire
20mm Single	Suits 1/2" 1 Wire
22mm Single	Suits 1/2" 2 Wire
25.4mm Single	Suits 5/8" 2 Wire
26.9mm Single	Suits 3/4" 1 Wire
28mm Single	
30mm Single	Suits 3/4" 2 Wire
32mm Single	
38mm Single	Suits 1" 2 Wire

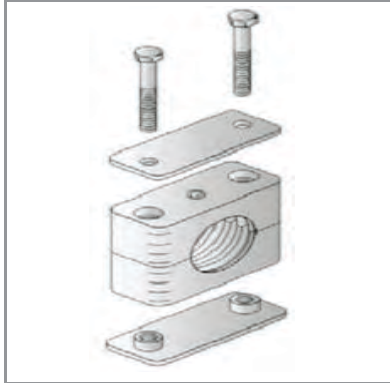

Clamps -Double-



Part Number	Description
8mm Double	
9.5mm Double	
12.7mm Double	Suits 1/4" 1 Wire
14mm Double	Suits 1/4" 2 Wire
15mm Double	
16mm Double	
18mm Double	Suits 3/8" 1 Wire
19mm Double	Suits 3/8" 2 Wire
20mm Double	Suits 1/2" 1 Wire
22mm Double	Suits 1/2" 2 Wire
25.4mm Double	Suits 5/8" 2 Wire
28mm Double	
30mm Double	Suits 3/4" 2 Wire
32mm Double	
38mm Double	Suits 1" 2 Wire

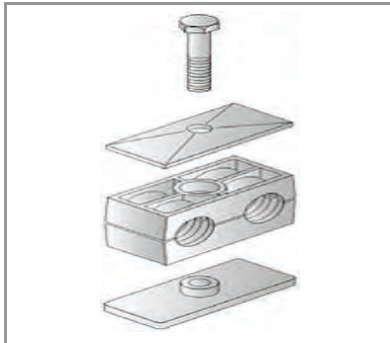

Ultra Heavy Duty Hose Clamps



Part Number	Description
SC17-19	
SC17-19W2	
SC174-187	
SC19-21W2	
SC21-23W2	
SC23-25	
SC23-25W2	
SC25-27	

Ultra Heavy Duty Hose Clamps Continued...



Part Number	Description
SC27-29W2	
SC29-31W2	
SC31-34 W2	
SC32-35	
SC32-35W2	
SC34-37W2	
SC37-40W2	
SC40-43W2	
SC43-47W2	
SC47-51W2	
SC51-55W2	
SC52-55	
SC55-59W2	
SC59-63W2	
SC63-68W2	
SC68-73W2	
SC73-79W2	
SC79-85W2	
SC85-91W2	
SC91-97W2	
SC97-104	
SC104-112	
SC112-121W2	
SC121-130W2	
SC130-140W2	

Cushion Clamps



Part Number	Description
PC6-1506	
PC10-2012	
PC12-2012	
PC13-2012	
PC16-2012	
PC18-2012	
PC19-2012	
PC22-2012	
PC24-2012	
PC26-2012	
PC28-2012	
PC30-2012	
PC31-2012	
PC32-2012	
PC38-2012	
PC50-2012	
PC60-2012	
PC67-2012	
PC70-2012	
PC90-2012	

Can't find what your looking for? Contact us -



1300 654 782



07 5428 1311

*All part numbers displayed in **BOLD ITALICS** are new items that may not be in stock as yet, please contact us for further details.*

BSPB O'Ring



Part Number	Size
BO02	1/8
BO04	1/4
BO06	3/8
BO08	1/2
BO12	3/4
BO16	1
BO20	1 1/4
BO24	1 1/2
BO32	2

BSPB Retaining Ring



Part Number	Size
BRRO02	1/8
BRRO04	1/4
BRRO06	3/4
BRR08	1/2
BRR12	3/4
BRR16	1
BRR20	1 1/4
BRR24	1 1/2
BRR32	2

ORFS Male O'Ring



Part Number	Size
ORORFS09	9/16
ORORFS11	11/16
ORORFS13	13/16
ORORFS16	1
ORUNO19	1 3/16
ORORFS23	1 7/16
ORORFS27	1 11/16
ORORFS32	2

UNO O'Ring



Part Number	Size
ORUNO07	7/16
ORUNO09	9/16
ORUNO12	3/4
ORUNO14	7/8
ORUNO17	1 1/16
ORUNO21	1 5/16

SAE Flange O'Ring



Part Number	Size
ORFL08	1/2
ORFL10	5/8
ORFL12	3/4
ORFL16	1
ORFL20	1 1/4
ORFL24	1 1/2
ORFL32	2

SAE Flange O'Ring (Viton)



Part Number	Size
ORFL12V	3/4
ORFL16V	1

BSP Self Centering Seal



Part Number	Size
QD-02	1/8
QD-04	1/4
QD-06	3/8
QD-08	1/2
QD-12	3/4
QD-16	1
QD-20	1 1/4
QD-24	1 1/2
QD-32	2
QD-KIT	Imperial Assortment Kit (See Kit Image Below)

Metric Self Centering Seal



Part Number	Size
QDM-12	12mm
QDM-14	14mm
QDM-16	16mm
QDM-18	18mm
QDM-20	20mm
QDM-22	22mm
QDM-24	24mm
QDM-26	26mm
QDM-34	34mm
QDM-42	42mm
QDM-48	48mm
QDM-KIT	Metric Assortment Kit



All of our Dowty seals are made from Nitrile NBR. Nitrile is based on Acrylonitrile Butadiene Copolymer material that is resistant to all mineral oils, water and watery liquids. It is also resistant to hot air and numerous other chemicals. Nitrile NBR is a general purpose rubber and is used in a variety of applications. **Operating Temperature Range -30°C - 110°C**

Can't find what your looking for? Contact us -



1300 654 782



07 5428 1311

All part numbers displayed in **BOLD ITALICS** are new items that may not be in stock as yet, please contact us for further details.

Hose Protector



Part Number	I.D. (mm)	O.D. (mm)	Roll Size (M)
R12SSG-AHF	9.50	12.50	50
R16SSG-AHF	12.50	16.00	20, 50
R20SSG-AHF	16.00	20.00	20, 50
R25SSG-AHF	21.00	25.00	20, 50
R32SSG-AHF	27.00	32.00	20, 50
R40SSG-AHF	34.00	40.00	20, 50
R50SSG-AHF	44.00	50.00	20, 50
R63SSG-AHF	55.00	63.00	20
R75SSG-AHF	66.00	75.00	20, 12
R90SSG-AHF	79.00	90.00	20, 12
R110SSG-AHF	99.00	110.00	12

AEROQUIP Scuff Cover - MSHA



Part Number	I.D. (mm)	To Suit Hose	Roll Size (M)
FC425-16	25.00	1/4"	91.44
FC425-18	28.75	1/4" - 3/8"	91.44
FC425-20	31.75	1/2"	91.44
FC425-28	44.45	1/2" - 3/4"	91.44
FC425-32	52.58	1"	91.44
FC425-38	60.45	1 1/4"	91.44
FC425-40	64.50	1 1/4"	91.44
FC425-46	72.64	1 1/2"	91.44
FC425-54	84.84	2"	91.44

Hose Restraints - Wire Cable Stockings



Part Number	Hose I.D. (mm)	Grip Length On Hose	Breaking Strength KG/kN
HR2010	10-14	350	1500 / 15
HR2014	14-19	400	2400 / 24
HR2019	19-28	500	3800 / 38
HR2028	28-40	600	5800 / 57
HR2040	40-50	800	5800 / 57
HR2050	50-60	900	10000 / 100
HR2060	60-70	900	10000 / 100
HR2070	70-85	1000	10000 / 100
HR2085	85-100	1000	16000 / 158
HR2100	100-120	1200	16000 / 158
HR2120	120-150	1400	21500 / 211
HR2150	150-190	1600	31000 / 305

Hose Cut Off Saw



UP TO 2"



LIGHTWEIGHT

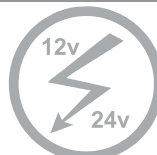

MULTI VOLTAGE



Part Number	Description
E-HC5110-12V	12v
E-HC5113-24V	24v
E-HC5102-240V	240v
E-HC11017-240V	240v Pull Down Type

You can cut up to 2" two wire hose or up to 1 1/4" four wire hose. Comes standard with a slotted blade to dissipate heat and increase blade life. These lightweight cut off saws are available in a variety of voltages - 12v, 24v and 240v. Great for mobile applications!

Hose Cut Off Saw (Floor Mounted)



UP TO 2"



FOOT OPERATION



3 PHASE POWER



Part Number	Description
E-HCC3	400v 50Hz 3 Phase 5.5Kw

Dimensions: 1000mm W x 1150mm H x 750mm D
Weight: 190kg

With this floor mounted hose cut off saw, you will be able to cut up to 2" six wire hose or 3" two wire hose. The E-HCC3 is a simple foot operated machine. This machine uses a 400mm slotted high speed steel cutting blade to dissipate and reduce heat. Great for the workshop and comes with connection for vacuum exhaust if available.

For more information on the above machine(s) please see the Hydralok website. www.hydralok.net



Can't find what your looking for? Contact us -



1300 654 782



07 5428 1311

All part numbers displayed in **BOLD ITALICS** are new items that may not be in stock as yet, please contact us for further details.

Mini Crimpers - Foot Operated



UP TO 1"



FOOT OPERATION



EASY CHANGE DIES



LIGHTWEIGHT



Crimp Force 1000Kn Hose Capacity 3/16" - 1" 4 Wire 100R12

Part Number		Description	
E-H25 Mini		Mini crimper with pneumatic foot pump	
The following dies are included			
Die No.	Range (mm)	Length	Ferrule Max Dia
A16OS	16.0 - 20.9	55	28
A21	21.0 - 23.9	50	33
A24	24.0 - 27.9	50	36
A28	28.0 - 30.9	60	40
A31	31.0 - 39.9	60	43
A40	40.0 - 45.9	60	46
A42*	42.0 - 47.9	60	52

Crimp up to 1" 4 wire hose with this light weight and compact mini crimper. Comes complete with a pneumatic foot pump for easy operation which requires 80-100 psi air supply. Hand pump version is also available.

(*Optional 42mm Die available on request)

Mini Crimpers - Hand Operated



UP TO 1 1/2"



NO POWER REQ



EASY CHANGE DIES



LIGHTWEIGHT



Crimp Force 1700Kn Hose Capacity 3/16" - 1" 4 Wire 100R12

Part Number		Description	
E-HE425-AIR		Vertical Crimper with hand pump	
The following dies are included			
Die No.	Range (mm)	Length	Ferrule Max Dia
A16OS	16.0 - 20.9	55	28
A21	21.0 - 23.9	50	33
A24	24.0 - 27.9	50	36
A28	28.0 - 30.9	60	40
A31	31.0 - 39.9	60	43
A40	40.0 - 45.9	60	46

Crimp up to 1 1/2" Two wire hose and up to 1" four wire hose, with this light weight and compact mini crimper. Crimp by using the hand pump, no electricity required - Great for remote applications.

For more information on the above machine(s) please see the Hydralok website. www.hydralok.net



Crimper - Mobile H32 Series



UP TO 1 1/4"

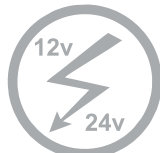

MULTI VOLTAGE



EASY CHANGE DIES



MOBILE FRIENDLY



DIGITAL CALIBRATION

(A)



(B)

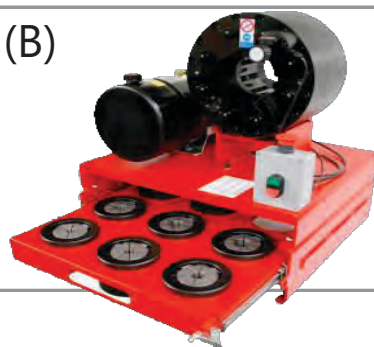

Part Number	Description		
E-H32MT4-12V	(A) Crimper No Quick Change tool or Draws		
E-H32MT4-12V-QCD	(B) Crimper Inc. Quick Change Tool & Draws		
E-H32MT4-24V	(A) Crimper No Quick Change tool or Draws		
E-H32MT4-24V-QCD	(B) Crimper Inc. Quick Change Tool & Draws		
The following dies are included			
Die No.	Range (mm)	Length	Ferrule Max Dia
H16OS	16.0 - 18.9	55	28
H19	19.0 - 20.9	40	31
H21	21.0 - 23.9	50	33
H24	24.0 - 27.9	50	36
H28	28.0 - 30.9	60	40
H31	31.0 - 33.9	60	43
H34	34.0 - 39.9	70	46
H40	40.0 - 43.9	70	52
H44	44.0 - 49.9	80	56
H50	50.0 - 54.0	80	62

- **Hose Capacity: 3/16" - 1 1/4" 4 Wire (1 1/2" 2 Wire with non standard dies)**

- **Crimper Force: 1750Kn**

- **Cycle Time: O/C 3.5 Sec - C/O 7.5 Sec**

The E-H32 series crimper is capable of crimping hose up to 1 1/4" four wire and up to 1 1/2" two wire, with an easy to use push button operation, and is available in 12v and 24v applications. Great for van set ups with it's lightweight and space saving design. Available with and without die draws.

For more information on the above machine(s) please see the Hydralok website. www.hydralok.net



Can't find what your looking for? Contact us -



1300 654 782



07 5428 1311

All part numbers displayed in **BOLD ITALICS** are new items that may not be in stock as yet, please contact us for further details.

Crimper - Mobile H50 Series



UP TO 1 1/4"

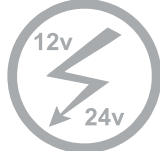

MULTI VOLTAGE



EASY CHANGE DIES



MOBILE FRIENDLY



DIGITAL CALIBRATION

(A)

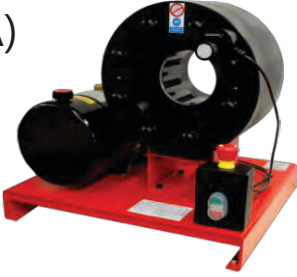

Part Number	Description
E-H50MT4-12V	(A) Crimper No Quick Change tool or Draws
E-H50MT4-12V-QCT-DRAWS	(B) Crimper Inc. Quick Change Tool & Draws
E-H50MT4-24V	(A) Crimper No Quick Change tool or Draws
E-H50MT4-24V-QCT-DRAWS	(B) Crimper Inc. Quick Change Tool & Draws

The following dies are included

Die No.	Range (mm)	Length	Ferrule Max Dia
L16OS	16.0 - 18.9	55	28
L19Q	19.0 - 20.9	40	31
L21Q	21.0 - 23.9	40	33
L24Q	24.0 - 27.9	50	36
L28Q	28.0 - 30.9	60	40
L31Q	31.0 - 33.9	70	43
L34Q	34.0 - 39.9	70	46
L40Q	40.0 - 43.9	70	52
L44Q	44.0 - 49.9	80	56
L50Q	50.0 - 54.4	80	62
L54.5Q	54.5 - 57.9	80	67
L58Q	58.0 - 61.9	80	70
L62Q	62.0 - 69.9	80	74
L70Q	70.0 - 76.9	95	82

(B)

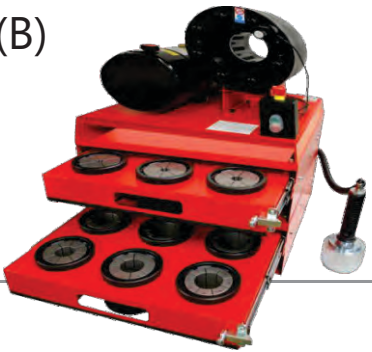

- **Hose Capacity: 3/16" - 2" 4 Wire**
- **Crimper Force: 2509Kn**
- **Cycle Time: O/C 4.0 Sec - C/O 8.0 Sec**

The E-H50 series crimper is capable of crimping hose up to 2" four wire, with an easy to use push button operation, and is available in 12v and 24v applications. Great for van set ups with it's lightweight and space saving design. Available with and without die draws.

For more information on the above machine(s) please see the Hydralok website. www.hydralok.net



Crimper - Mobile H50-46 Series



UP TO 1 1/4"

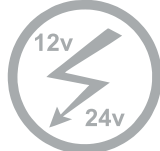

MULTI VOLTAGE



EASY CHANGE DIES



MOBILE FRIENDLY



DIGITAL CALIBRATION

(A)

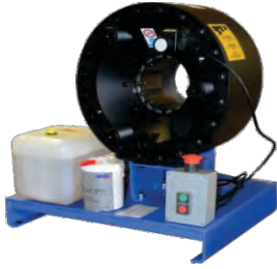

(B)

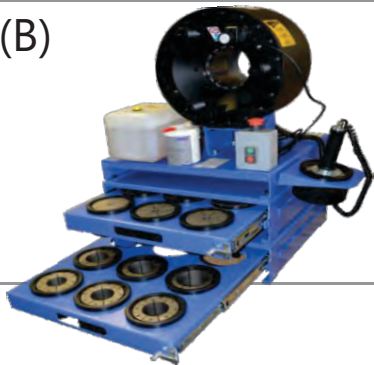

Part Number	Description		
E-H50MT46-12V	(A) Crimper No Quick Change tool or Draws		
E-H50MT46-12V-QCT-DRAWS	(B) Crimper Inc. Quick Change Tool & Draws		
E-H50MT46-24V	(A) Crimper No Quick Change tool or Draws		
E-H50MT46-24V-QCT-DRAWS	(B) Crimper Inc. Quick Change Tool & Draws		
The following dies are included			
Die No.	Range (mm)	Length	Ferrule Max Dia
M16OS	16.0 - 18.9	55	28
M19Q	19.0 - 20.9	40	31
M21Q	21.0 - 23.9	40	33
M24Q	24.0 - 27.9	50	36
M28Q	28.0 - 30.9	60	40
M31Q	31.0 - 33.9	70	43
M34Q	34.0 - 39.9	70	46
M40Q	40.0 - 43.9	70	52
M44Q	44.0 - 49.9	80	56
M50Q	50.0 - 54.4	80	62
M54.5Q	54.5 - 57.9	80	67
M58Q	58.0 - 61.9	80	70
M62Q	62.0 - 69.9	80	74
M70Q	70.0 - 76.9	95	82
M77Q	77.0 - 83.0	120	89

The E-H50-46 series crimper is capable of crimping hose up to 2" four wire, with an easy to use push button operation, and is available in 12v and 24v applications. Great for van set ups with it lightweight and space saving design. Available with and without die draws.

For more information on the above machine(s) please see the Hydralok website. www.hydralok.net



Can't find what your looking for? Contact us -



1300 654 782



07 5428 1311

All part numbers displayed in **BOLD ITALICS** are new items that may not be in stock as yet, please contact us for further details.

Crimper - Hydratouch Series



UP TO 2"



EASY CHANGE DIES



FOOT OPERATION



TOUCH SCREEN



MULTI VOLTAGE



Part Number	Dies	Description
E-H32CE4Q	H Series	1 1/4" 4 Wire 240v Machine (10 Dies)
E-H50CE4Q	L Series	2" 4 Wire 240v Machine (14 Dies)
E-H50CE46Q	M Series	1 1/2" 6 Wire 3 Phase Machine (15 Dies)
E-H50CE6Q	M Series	1 1/2" 6 Wire 3 Phase Machine (15 Dies)

The following dies are included (Depending on machine ordered)

Die No.	Range (mm)	Length	Ferrule Max Dia
M16FC	16.0 - 18.9	55	28
M19	19.0 - 20.9	40	31
M21	21.0 - 23.9	50	33
M24	24.0 - 27.9	50	36
M28	28.0 - 30.9	50	40
M31	31.0 - 33.9	60	43
M34	34.0 - 39.9	70	46
M40	40.0 - 43.9	85	52
M44	44.0 - 49.9	80	56
M50	50.0 - 54.4	80	62
M54.5	54.5 - 57.9	100	67
M58	58.0 - 61.9	105	70
M62	62.0 - 69.9	110	74
M70	70.0 - 76.9	110	82
M77	77.0 - 83.0	120	89



The Hydratouch series crimper is capable of crimping hose up to 2" four wire and 1 1/2" six wire, with an easy to use foot pedal or button operation and new touchscreen technology for easy crimp selection and updating. The Hydratouch Series is available in single and 3 Phase power options depending on model ordered.

Great for workshop set ups. Comes with die rack as shown.

While M Series dies are shown on the table above, simply change the first letter of the die to correspond with the die series shown on the machines above.

For more information on the above machine(s) please see the Hydralok website. www.hydralok.net



Crimper - ECO Series



UP TO 2"



EASY CHANGE DIES



FOOT OPERATION



DIGITAL CALIBRATION



MULTI VOLTAGE



Part Number	Dies	Description	
E-H32B4 (ECO)	H Series	10 Sets	
E-H50B4 (ECO)	L Series	14 Sets	
E-H50B46 (ECO)	M Series	15 Sets	
The following dies are included			
Die No.	Range (mm)	Length	Ferrule Max Dia
M16FC	16.0 - 18.9	55	28
M19	19.0 - 20.9	40	31
M21	21.0 - 23.9	50	33
M24	24.0 - 27.9	50	36
M28	28.0 - 30.9	50	40
M31	31.0 - 33.9	60	43
M34	34.0 - 39.9	70	46
M40	40.0 - 43.9	85	52
M44	44.0 - 49.9	80	56
M50	50.0 - 54.4	80	62
M54.5	54.5 - 57.9	100	67
M58	58.0 - 61.9	105	70
M62	62.0 - 69.9	110	74
M70	70.0 - 76.9	110	82
M77	77.0 - 83.0	120	89

The ECO series crimper is capable of crimping hose up to 2" six wire, with an easy to use foot pedal or button operation. The Eco series is available in single and 3 Phase power options depending on model ordered. Great for workshop set ups at a lower up front cost. Comes with die rack as shown.

While M Series dies are shown on the table above, simply change the first letter of the die to correspond with the die series shown on the machines above.

For more information on the above machine(s) please see the Hydralok website. www.hydralok.net



Can't find what your looking for? Contact us -



1300 654 782



07 5428 1311

All part numbers displayed in **BOLD ITALICS** are new items that may not be in stock as yet, please contact us for further details.

Hydraflare



UP TO 1"



PRESSURE GAUGE



NO POWER REQ



LIGHTWEIGHT



Part Number		Description	
E-HF1		Hydraflare Tool with Hand Pump	
The following dies are included			
Die No.	Tube	To Suit	
E-PF1-04	1/4"	7/16" JIC	
E-PF1-05	5/16"	1/2" JIC	
E-PF1-06	3/8"	9/16" JIC	
E-PF1-08	1/2"	3/4" JIC	
E-PF1-10	5/8"	7/8" JIC	
E-PF1-12	3/4"	1 1/16" JIC	
E-PF1-16	1"	1 5/16" JIC	

You can flare tube from 1/4" up to 1" using a Twin speed hand pump, with an integral relief valve. The hand pump produces up to 690bar (10,000psi) and comes with an easy to read Pressure Gauge.

For more information on the above machine(s) please see the Hydralok website. www.hydralok.net



Hydrastatic Hose Tester



PRESSURE GAUGE



HIGH PRESSURE



LIGHTWEIGHT



Part Number		Description	
BPT-G175WL			

The ShinEast Hydrastatic Hose Tester is a great mobile or workshop solution for testing hoses. This machine can test any size hose up to 140Mpa (20,300 psi) The Hydrastatic Tester has easy to read pressure gauge and is mounted on four caster wheels for easy movement. Please note that this machine does not come with a containment cabinet.